

NOTE:

1. CABLE IS ATTACHED TO THE RIGHT SIDE OF TOUCH PANEL AS SHOWN.
2. TAIL CONNECTOR: PITCH 2.54mm
3. AMP CONNECTOR P/N : 487526-3.

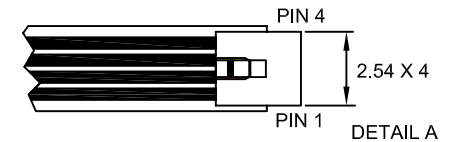
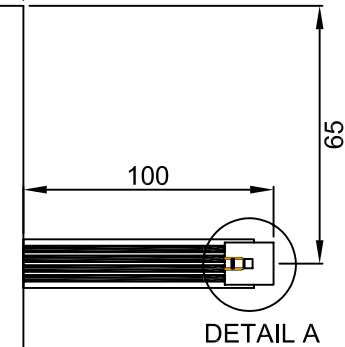

P/N	COVERSHEET TYPE	GLASS THICKNESS	FINISHED PART THICKNESS
4WR1202AG2	CLEAR	1.8	2.1 ± 0.2
4WR1202AN2	ANTI-GLARE		

CONNECTOR PINOUT	
PIN NO	ASSIGNMENT
1	Y down
2	X right
3	Y up
4	X left

宇鴻光電股份有限公司
ATouch Technologies Co., Ltd.

MODEL NUMBER		4WR1202AA2
DRAWN BY	DIMENSION UNIT	ISSUE DATE
KEN JHUANG	mm	12 / 19 / 07
CHECKED BY	SCALE	REV
MELISSA WEI	NOT TO SCALE	E